

## EN 50366 – only for Europe?

### Manufacturers, importers and retailers of household appliances can profit from compliance tests

The visibility of mobile network antennas means that we are aware of being surrounded by electromagnetic radiation. What most of us forget, though, is that we are exposed to a cocktail of electric and magnetic waves just by staying at home. This fact prompted two Technical Committees within CENELEC, the European Committee for Electrotechnical Standardization, to consider the subjects “Electromagnetic Fields Around Household and Similar Electrical Appliances” and “Electromagnetic Fields in the Human Environment”. The result of their studies was the new European Norm (EN) 50366. All EU member states had to incorporate the regulations in this standard into their own national standards by February 1, 2004, and all conflicting standards are to be withdrawn by February 1, 2006.

### The CE mark – a must for manufacturers, importers and retailers

Is this purely a European affair? No, indeed. Compliance with EN 50366 is mandatory since February 2004 for the award of the CE mark. This means that all manufacturers outside the EU must also perform the tests prescribed by EN30566 if they want their products to be imported into the EU area. This involves some expense, which can only be kept to a reasonable level by the use of practical test equipment. On the other hand, clients outside the EU will also benefit from this tried and tested safety – a bonus for manufacturers, importers and retailers.



*Fig. 1: Testing a domestic appliance at the specified distance. The probe contains three mutually perpendicular coils with a cross sectional area of 100 cm<sup>2</sup> as prescribed in EN 50366.*

## **A significant part of safety engineering: The magnetic field**

The rule of thumb that voltage causes electric fields and current causes magnetic fields is incorrect. Alternating fields always have both electrical and magnetic components. But, as far as the safety of domestic appliances is concerned, it is the magnetic component that is significant. EN 50366 therefore concentrates on describing the measurement of magnetic fields in the range 10 Hz to 400 kHz, and on specifying appropriate reference levels. There is a separate standard, EN 60335, and a different test procedure for microwave ovens that utilize high frequency energy.

### **The distance factor**

Distance is a vital factor in the measurement. An electric shaver is only useful if it is in direct contact with skin. But you would hardly put your hand on a hotplate – and keeping your distance would not be because you are worried about magnetic fields. This can be taken into account when evaluating the generated fields. The Appendix to EN 50366 therefore names a whole range of types of applications and specifies the distances at which measurements should be made.

### **The evaluation factor**

The absolute value of the magnetic field is not the deciding factor. The effect of a field on humans also depends on its frequency. The norm therefore defines a transfer function, which is automatically taken into account by suitable measuring equipment. The result is frequency-weighted.

Time-domain evaluation is more difficult. The result should represent the RMS value, regardless of the signal shape – including impulsive signals.

### **The directionality factor**

A further factor involves the mechanics of the measurement. Coils are useful as magnetic field sensors, but they only work in one direction. The result, however, has to be non-directional. This means that three coils arranged in a mutually perpendicular configuration are needed in order to measure the actual field strength. This, in turn, is given by adding together the power levels, not the induced voltages. So a calculation that takes the square root of the sum of the squares is involved.

### **Time Domain Evaluation as a reference method**

EN 50366 describes several methods. The most elegant is called Time Domain Evaluation, and it yields the fastest and most reliable results. In consequence, it is designated as the reference method to be used in case of doubt.

The principle (fig. 2) is simple: The circuit evaluates the individual components according to the transfer function, sums the real power levels in the time domain (in real time) and determines the true RMS value by taking the average and the square root.

In contrast, spectrum analysis or Line Spectrum Evaluation is complicated and can lead to erroneous results. This is because the signals from the three coils are measured one after the other, their spectra developed and the true power levels of the individual spectral lines added together. This cannot be done in real time, so there is a wait for the results and random peak values in any direction may go unrecorded.

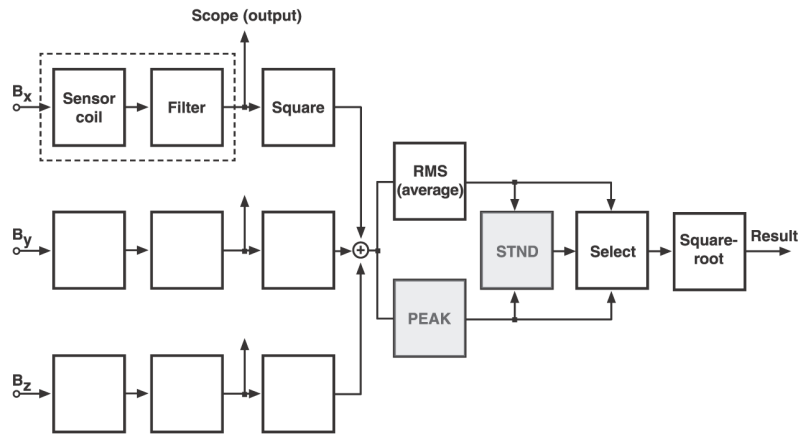

Fig. 2: Diagram of the reference method according to EN 50366. Scope (oscilloscope output), PEAK (peak value detector) and STND (standard) are special features of the Narda Safety Test Solutions ELT-400 test set, which can also evaluate fields on the basis of other standards.

### High measurement accuracy – an advantage for manufacturers and users

What most people call measurement accuracy is known in the trade as measurement uncertainty. It is not a measurement error, since errors can be corrected. It is rather the range within which the result indicated by the test set may deviate from the actual value. Reputable manufacturers of test equipment always quote this factor in specifications and calibration certificates.

If a domestic appliance manufacturer wants to demonstrate that the product does not generate impermissibly high field levels, the measurement uncertainty has to be added to the measured value. In other words, if the measurement uncertainty is 25%, the measured value must not exceed 75% of the limit value to comply with the norm.

Conversely, authorities or consumer organizations have to subtract the measurement uncertainty from the measured value. Proof that a product exceeds the limit value is only given if the measured value is more than 25% higher than the limit value.

A low measurement uncertainty is therefore in the interests of end users, who are looking for safety. It is also in the manufacturer's interests, to be able to claim honestly that an appliance is not only "good", but that it is also CE compliant.



Fig. 3: The Exposure Level Tester ELT-400 from Narda Safety Test Solutions precisely implements the Time Domain Evaluation method laid down in EN 50366, and displays the result immediately.

**Related links:**

[www.cenelec.org/Cenelec/Homepage.htm](http://www.cenelec.org/Cenelec/Homepage.htm)

[www.uk.tuv.com/web/index.html](http://www.uk.tuv.com/web/index.html)

[www.industrialsafetytalk.com/news/tvi/tvi000.html](http://www.industrialsafetytalk.com/news/tvi/tvi000.html)

[www.narda-sts.de](http://www.narda-sts.de)

*The Autor:*

*Dipl.-Ing. Burkhard Braach is a freelance trade journalist based in Reutlingen.*

October 2005

Subject to change without notice

**© Narda Safety Test Solutions GmbH**

Sandwiesenstr. 7

72793 Pfullingen

Germany

Phone +49 7121 9732-777

Fax +49 7121 9732-790

E-mail [support@narda-sts.de](mailto:support@narda-sts.de)

[www.narda-sts.de](http://www.narda-sts.de)