

23. Measurement of an Electric Field of a Scanning Radar Antenna Dina Šimunic, Helmut Keller* and Zlatko Koren

University of Zagreb, Faculty of Electrical Engineering and Computing, Dept. for Radiocommunications and Microwave Engineering, Unska 3, HR-10000 Zagreb, Croatia
*Wandel & Goltermann, Elektronische Messtechnik, Muehleweg 5, D-72800 Eningen u.A., Germany

Abstract - This paper presents a novel method for measuring true root-mean-square and peak values of an electric field strength generated by a scanning radar antenna. The measuring equipment is a new electric field meter with an isotropic probe based on a diode detector, specifically designed for applications in pulsed environment. The idea of the method is a compensation of detector's inertia for measuring very short pulses with a very low duty cycle ratio. Correction curves needed for such compensation are generated by simulating both: characteristics of a detector and four parameters of a scanning radar antenna. The curves provide a correction factor relating a peak and a displayed electric field value. Verification of the simulated models has been performed by laboratory measurements for two different probes (frequency range: 100 kHz – 3 GHz and 10 MHz – 18 GHz). The method has been tested at on-site measurements of a typical airport surveillance radar. The presented method represents an improved solution for pulsed fields measurements during normal operating modes of radar transmitters to the raised issue of electromagnetic field "dosimetry".

I. INTRODUCTION

Measurement of high frequency pulsed electromagnetic fields, as for instance signals generated by scanning radar antennas has been for a long time reserved only for measurements performed by a spectrum analyzer and a wide frequency band antenna. The main disadvantage of this solution is its inconvenience for the application in electromagnetic field "dosimetry". For a small, inexpensive electric field meter the pulsed environment of a scanning radar antenna has been an unsolved measuring problem. This kind of measurement is of an especial interest in a raised problem of a possible health risk from very high peak microwave power pulses of radar transmitters, even though the proven effect "microwave hearing" has not been shown to be adverse [1]. Also, new guidelines, such as IRPA/ICNIRP [2] and the European prestandard ENV-50166-2 [3] ask for solving the problem.

The term "electric field meter" encompasses an electrically small and thin dipole antenna, a detector mounted across the gap of the dipole, electric field non-perturbing high-resistive lines, carrying the detected signal to the instrument for further processing and the instrument itself. An isotropic response is achieved by three dipoles in proper space orientations. Nowadays existing electromagnetic fields measuring equipment uses mostly two kinds of detectors: thermocoupler- and diode-based. The both of them have advantages and disadvantages, as explained thoroughly in [4].

Insofar, measurements have been performed by a radar antenna standing still ("static case") using an advantage of thermocoupler detectors - power integration in time, giving true root-mean-square (RMS) value. Unfortunately, this is not always possible, because very often a radar operation should not be blocked (e.g. air traffic control). When the radar antenna is scanning, then the detectors

containing thermocouples have several main disadvantages - sensitivity to a short term or minor overload; they are too slow to be applied in such measurements (response time typically 1.5 s [5], while radar pulses could be much faster); too low sensitivity (typically 10 V/m) for measuring pulses at distant locations [6].

Diode detectors have not been used in electric field meters for measuring high-peak short pulses, because the behavior of the diode changes with an input electric field strength. But, diode as a detector has also some advantages over a thermocoupler, i.e. it is much faster, it has a much higher dynamic range, necessary for handling peak electric fields (60 dB) and it can be protected from the overload. In this paper it is proven that a knowledge of a behavior of components of the whole measuring device with a diode detector to a pulsed electromagnetic field can be used in making correction curves, necessary for a compensation of the non-ideal physical response. The advantages of diode detectors can now be combined with the knowledge of the sensor response to complex signals. This opens the doors to many new applications, i.e. measurements at rotating radar systems.

II. IDEAL MEASURING INSTRUMENT FOR SHORT HIGH-PEAK MICROWAVE PULSES

The first step to start solving this problem is to describe microwave pulses which would further enable defining an ideal electric field measuring equipment.

The most important parameter of microwave pulses generated by a radar transmitter is a duty cycle or duty factor. Duty cycle is a ratio of a pulse duration (PD) to a pulse repetition time (PRT). The duty cycle of air traffic control radar transmitters has typically ratio of 1:1000. Fig. 1 shows a normalized amplitude spectrum for a pulse train with PD = 3.3 μ s and pulse repetition frequency of 340 Hz.

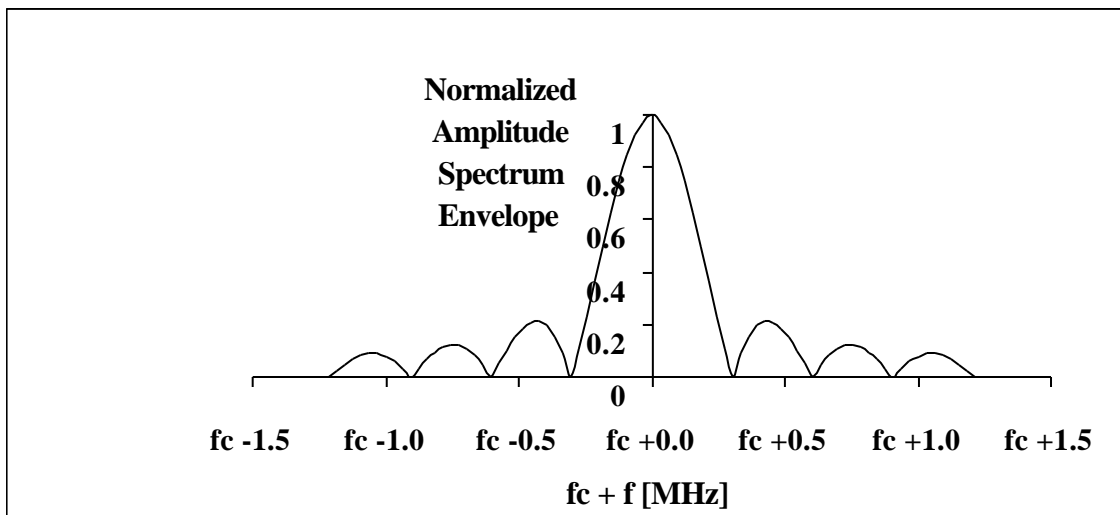

Fig. 1 Frequency spectrum of a radar pulse train

The most important property of the equipment should be an immediate response ($\sim 1 \mu$ s or less), because of the short duration of scanning radar pulses. Then, the antenna system should consist of three dipoles, so that the measured field does not depend on a receiving polarization

(a field isotropy). The next requirement for applying the measuring device in "dosimetric" purposes stems from guidelines and standards. The new European prestandard ENV 50166-2: "Human exposure to electromagnetic fields - High frequency (10 kHz to 300 GHz)" [3] gives limit value for pulsed fields as a peak value of an electric field strength [V/m]. The IRPA/INIRC guidelines, chapter 5 "Guidelines on limits of exposure to radiofrequency electromagnetic fields in the frequency range from 100 kHz to 300 GHz" [2] give a value for a peak electric field as an equivalent plane wave field strength as averaged over the pulse width which should not exceed 32 times the field strength limits for continuous wave case. Therefore, according to the mentioned guidelines for the pulsed field the ideal device should show a peak electric field value on the display. The last, fourth property is optional and it depends on a distance from a source. If a measuring position is in a near field, then the both fields, i.e. electric and magnetic field, should be measured isotropically and simultaneously. This idea has been described theoretically and verified experimentally in [7] for a single sensor. The simultaneous measurement is necessary, because a simple relation between electric field, power density and free space impedance does not hold any longer.

III. CHARACTERISTICS OF THE REAL DIODE DETECTOR

According to [8] the output DC voltage V_o is for the small induced steady-state voltage V_i :

$$V_o = -\frac{\alpha}{4} \left(\frac{V_i}{1 + C_d / C_a} \right)^2 \quad (1)$$

and for the large induced voltage V_o is:

$$V_o = -\frac{V_i}{1 + C_d / C_a} \quad (2)$$

In the above equations C_d is a combination of a diode parasitic capacitance and a junction capacitance; C_a is a dipole capacitance; $\alpha = q / nkT$, where k is Boltzmann's constant, q is electron charge, T is temperature in °K and n is diode ideality factor.

The two equations indicate that at lower steady-state signal levels the diode detector acts following a square-law and at higher levels it acts as a linear detector: the output voltage is proportional to the input voltage. Therefore, if the electric field meter consists of three probes, as an isotropic measurement system, then it is possible to compensate the property of a diode detector for a steady-state. Compensation has to be done before summing: this means that a signal of each sensor is corrected to give an overall quadratic value; then the signals are summed; finally we use the root to calculate the E-field. The problems begin to occur when measuring pulsed fields, because the instruments are typically calibrated using single-frequency, single-source standard fields. The theoretical analysis of multiple-source, multiple-frequency error for a single antenna with a diode detector has been elaborated in [9]. Since pulsed fields are not monochromatic (Fig. 1), an error can occur in displayed value, which is different from the true RMS and the true peak value. According to [9], diodes are peak detectors for high field strengths. For the multiple-frequency signals this is true only for a high modulation frequency. At low modulation frequencies the detector can show results that are even less than a RMS detector would show. The intention of the work has been fixing a difference between displayed and true RMS and peak values and correcting the error.

IV. MATERIALS AND METHOD

The described electric field meter is represented by a W&G EMR-300 with two broadband probes (probe 1 with a frequency range: 100 kHz-3 GHz and probe 2 with a frequency range from 10 MHz to 18 GHz). The equivalent circuit of the measuring W&G EMR-300 (Fig. 2) has been simulated transiently by PSPICE. A dipole is represented by a resistance R_0 and a capacitor C_0 . Capacitance C_P represents a parasitic capacitance. A beam lead Schottky diode is represented by a junction capacitance C_J , dependent on an induced voltage. The symbol of a diode stands for a nonlinear diode resistance R_D , characterized by the u-i characteristic:

$$i(t) = I_s \left(e^{\frac{V_d}{N \cdot V_t}} - 1 \right) \quad (3)$$

where I_s is a saturation current, V_d is a voltage across the intrinsic diode only, N is an emission coefficient (≈ 1) and V_t is a thermal voltage ($= kT/q$ -the parameters same as above).

Since dipoles of the both examined probes are electrically short at frequency of 1 GHz ($l_1 = 30$ mm for probe 1 and $l_2 = 0.8$ mm for probe 2), they are represented only by the capacitance C_0 .

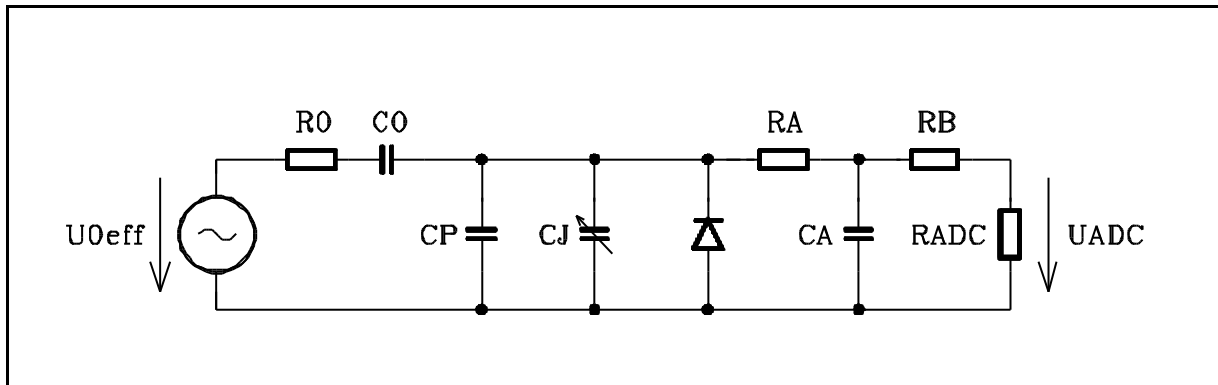

Fig. 2 Equivalent circuit of W&G EMR-300 for a transient analysis

Discrete circuit element CA is chosen large enough to serve as a short circuit for the high frequency current in order to prevent picking up a high frequency signal by the high resistive leads (represented by RB). The resistance $RADC$ is a high resistive input to the device. The source $U_0\text{eff}$ is a voltage steady-state source.

Probe 1 has a frequency range from 100 kHz to 3 GHz. Its typical frequency behavior is given in [11] and a linearity deviation at reference frequency 27.12 MHz in [12]. Probe 2 covers a frequency range from 3 MHz to 18 GHz and its frequency behavior could be seen in [13]. However, a dynamic behavior of the probes has not been measured in a pulsed environment. Therefore, the results of the simulation have been compared to the results of measurements performed in the laboratory.

The measurements have been performed with a generator (HP 8350A), broadband amplifier (Amplifier Research Model 4W1000), log-periodic antenna (Rohde & Schwarz HL025, 1...18 GHz) and the electric field meter Wandel & Goltermann, EMR-300 with the probes 1 and 2 on a wooden tripod [10].

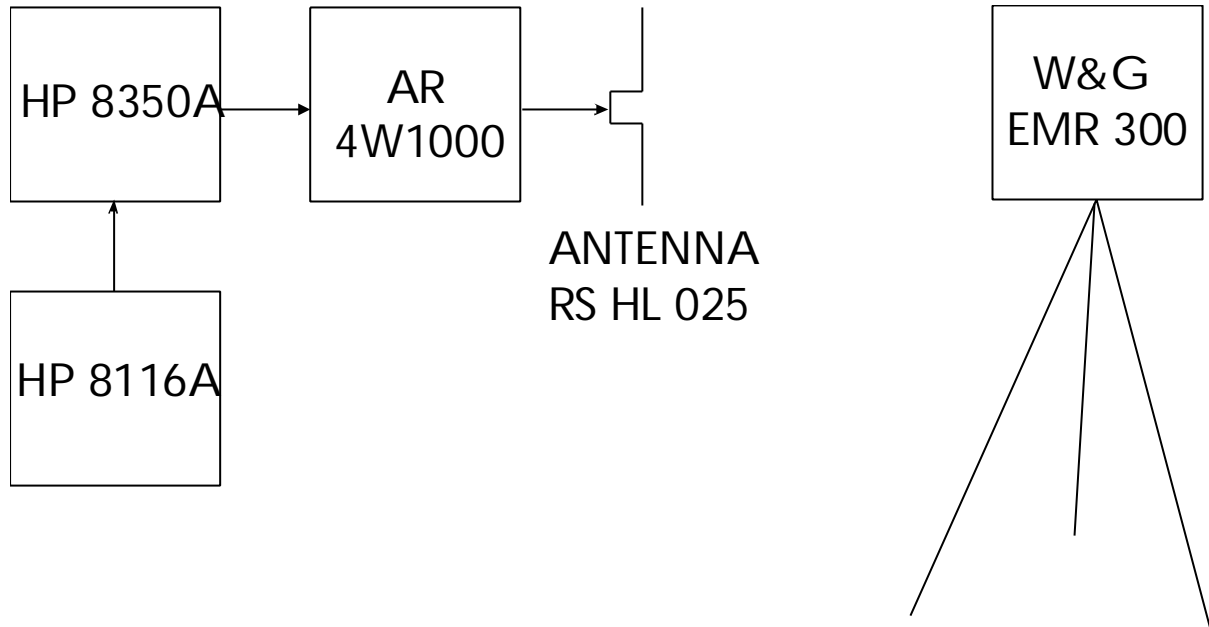

Fig. 3 The measurement set-up

The measurements have been performed in a near field zone, because the both probes are electrically small at 1 GHz. To the measurement set-up a pulse-function generator (HP 8116 A) has been added. Pulses from the pulse generator have modulated a high-frequency output. The chosen duty cycle was $1.122 \cdot 10^{-3}$ with pulse duration of $3.3 \mu\text{s}$ and pulse repetition frequency being 340 Hz.

The electric field has been measured with continuous wave signal and afterwards with the pulsed field.

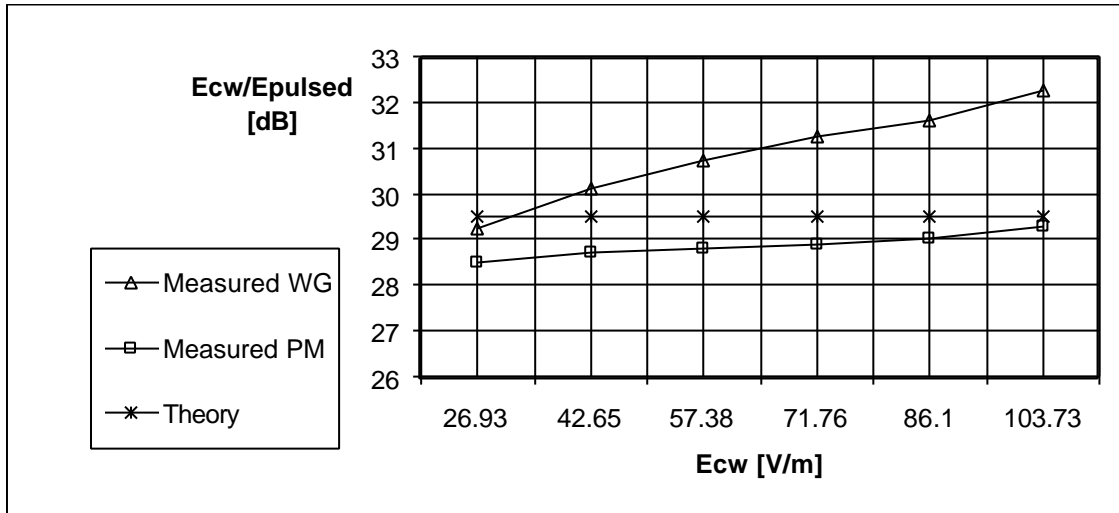

Fig. 4 Ratio of continuous wave and pulsed field displayed by the meter, by the power meter and theoretically calculated values for probe 1

Fig. 4 depicts a difference between values displayed on the electric field meter W&G EMR-300 with the probe 1, values measured by power meter and the theoretically calculated difference (29.5 dB). At lower electric fields the meter shows smaller values than the real values (~1.5 dB); at higher levels it shows also less than it should and the difference to the theoretical value becomes higher (~3.05 dB). Obviously, for this duty cycle the correction of the displayed electric field values is needed at all electric field levels.

Fig. 5 shows the results of the same kind of measurements and theoretical values for probe 2. It is seen that the behavior is similar to probe 1, although the difference to the theoretical value is somewhat smaller: at lower electric fields level it is negligible, at higher levels it is ~0.4 dB.

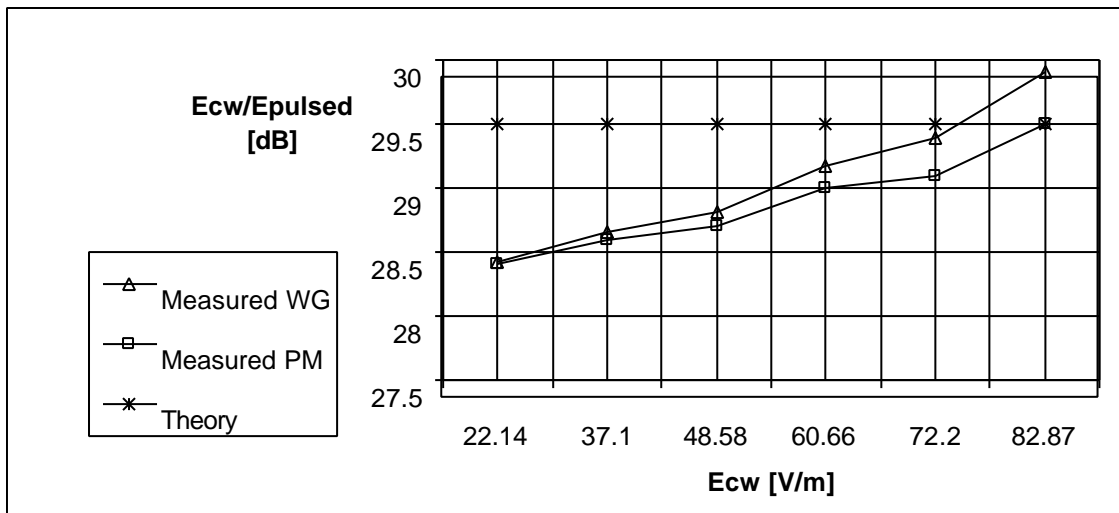

Fig. 5 Ratio of continuous wave and pulsed field displayed by the meter, by the power meter and theoretically calculated values for probe 2

In order to simulate pulsed fields and to get the needed correction factors, the simulation model from Fig. 2 has been extended by introducing the second source V_2 , defining duty cycle. This has been done for the instrument with the both probes. The chosen parameters for the pulse duration ($3.3 \mu\text{s}$) and pulse repetition frequency (340 Hz) are taken the same as for the performed measurements. The results of the simulation, giving correction factors in terms of $E_{\text{rms}}/E_{\text{display}}$, are shown in Fig. 6 for probe 1 and in Fig. 7 for probe 2. The correction factor $E_{\text{rms}}/E_{\text{display}}$ is called the "static" correction factor, because it is applied when a radar antenna is standing still.

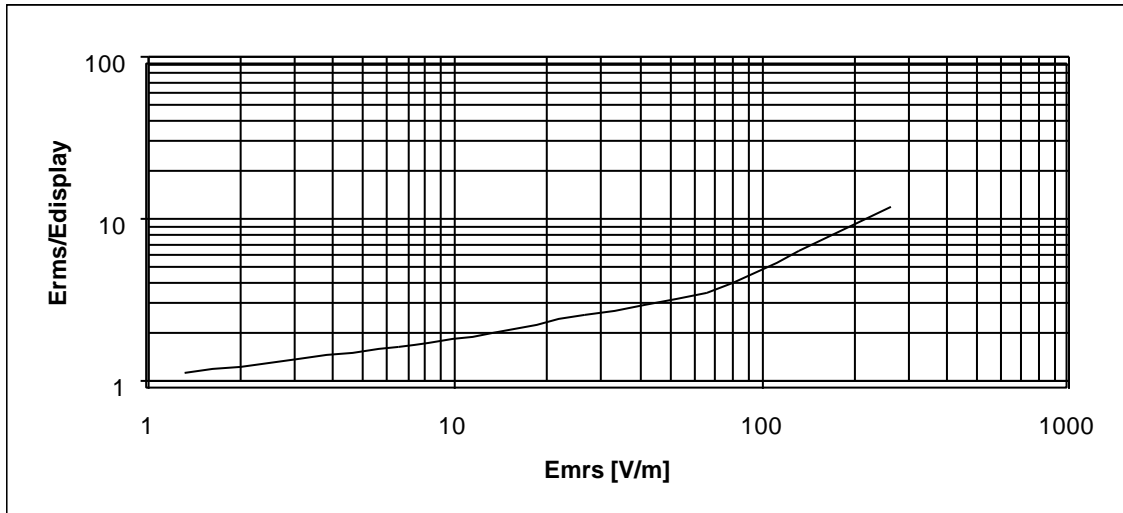

Fig. 6 "Static" correction curve for probe 1 (simulation)

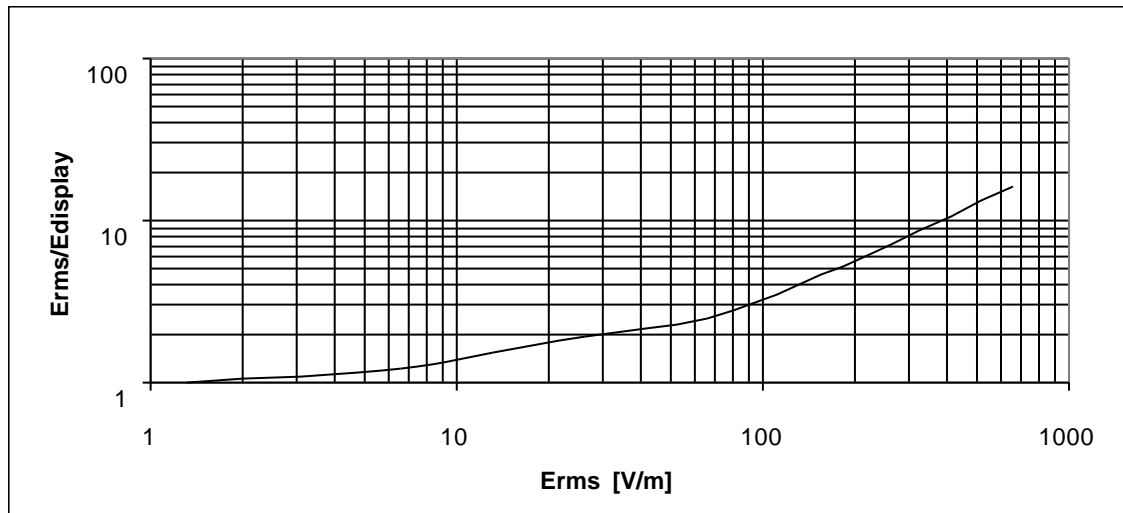

Fig. 7 "Static" correction curve for probe 2 (simulation)

After obtaining the curves, the "static" correction factor has been applied to the displayed measured values in the laboratory.

Figs. 8a and 8b show the comparison of the measurement results corrected with the "static" factor from the simulation (Figs. 6 and 7) and the measured values with power meter for the both probes.

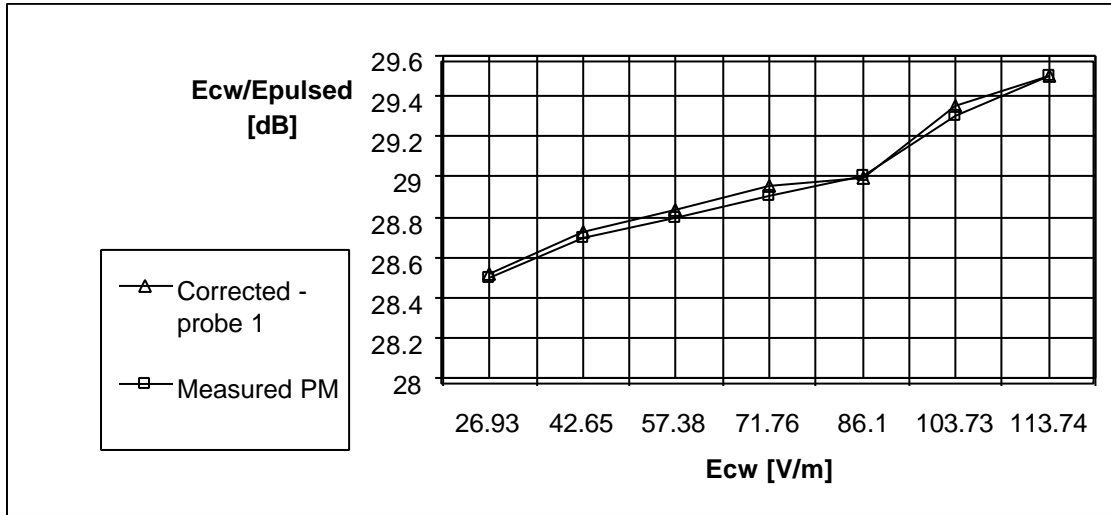

Fig. 8a Ratio of continuous wave and pulsed field displayed by the meter and corrected according to the simulated curves (Fig. 6) and the measured values with power meter for the probe 1

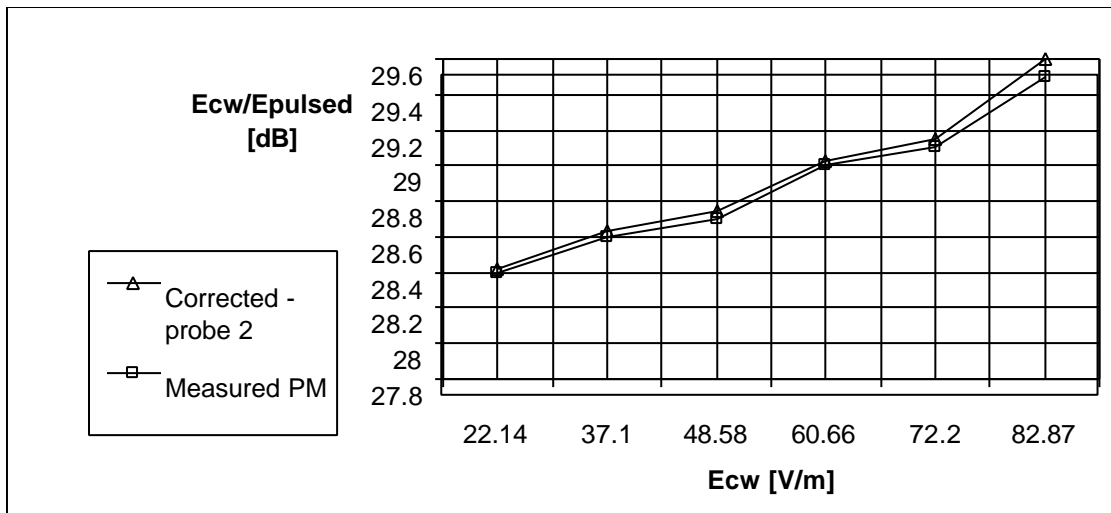

Fig. 8b Ratio of continuous wave and pulsed field displayed by the meter and corrected according to the simulated curve (Fig. 7) and the measured values with power meter for the probe 2

V. SCANNING RADAR MEASUREMENTS RESULTS

The final aim of this work has been to measure pulsed fields generated by the scanning radar. We chose a typical representative of the airport surveillance radar family, having the following characteristics: a L-band radar (operating frequency 1.3 GHz), PD = 3.3 μ s, PRF = 340 Hz, aerial rotation speed = 5 rpm and antenna beam width = 1.2°. At one position 13.6 pulses during 40 ms are to be received.

As mentioned before, the guidelines [2] and the prestandard [3] require a peak value to be measured. Therefore, a curve giving a relation between the value displayed on the instrument and the same value ($E_{\text{peak}}/32$) divided by E_{display} [$(E_{\text{peak}}/32)/E_{\text{display}}$] has been needed to be simulated.

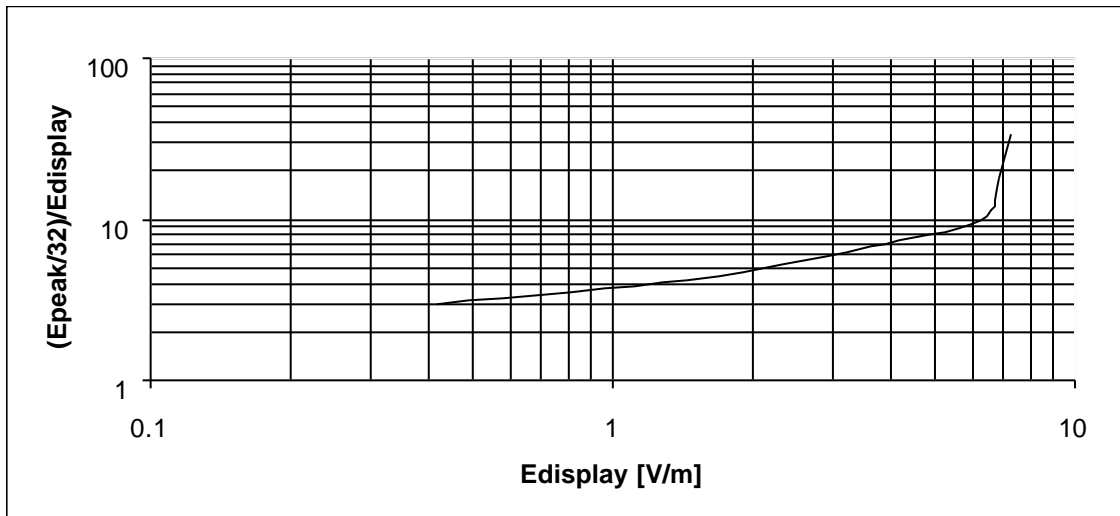

Fig. 9 "Dynamic" corrective curve (probe 1) for the air surveillance radar

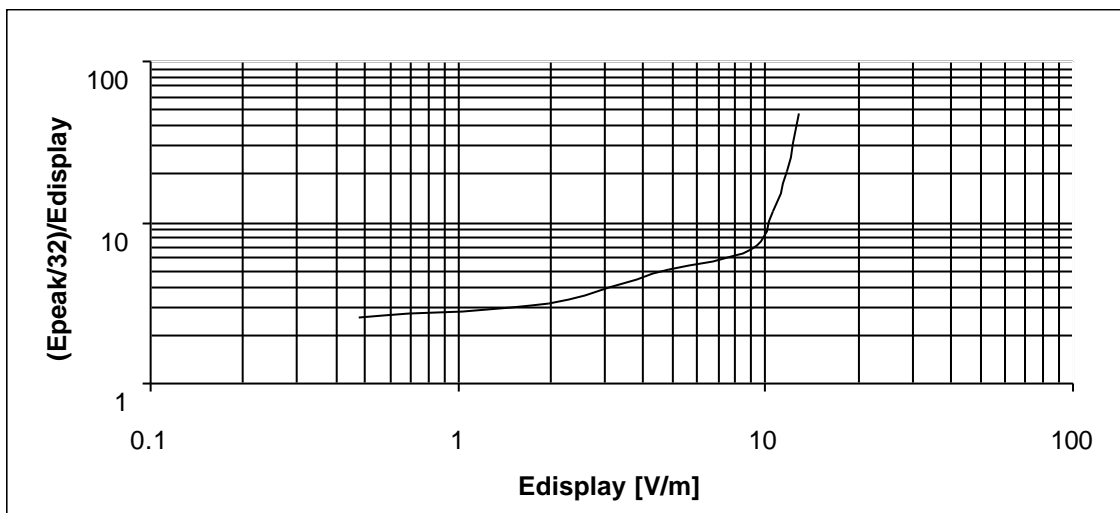

Fig. 10 "Dynamic" corrective curve (probe 2) for the air surveillance radar

The displayed value at 500 m from the radar has been 2.35 V/m (probe 1), which gives a "dynamic" correction factor of 5.257 according to the curve in Fig. 9. The final $E_{\text{peak}}/32$ value of 12.35 V/m has been calculated by multiplying the "dynamic" correction factor with the displayed value. The peak value is obtained by multiplying $E_{\text{peak}}/32$ with 32, i.e. E_{peak} is 395.3 V/m. According to the theory the peak value in the direction of maximum radiation should be 913.7 V/m at 500 m distance. The difference appeared because the radar transmitter is installed at the height of 20 m, and the measurements have been performed on the ground, i.w. not in the direction of the maximum radiation. The displayed value at the same distance for the probe 2 has been 3.15 V/m. With a "dynamic" correction factor of 3.98 (Fig. 10) this gives a $E_{\text{peak}}/32$ of 12.54 V/m and E_{peak} of 401.3 V/m. As expected, the different probes gave different displayed values in the pulsed field, but after correcting them by the transiently simulated "dynamic" correction factors the difference in E_{peak} values has been 1%, which is negligible. Therefore, the conclusion is that the both simulation models are very well established.

VI. CONCLUSION

The electric field meter W&G EMR-300 [10] with the two broadband probes has been transiently simulated in order to realize and compensate errors occurring due to the non-ideal behavior of the instrument in the short high peak pulsed electric fields. The probes are based on a diode detector and the instrument has afterwards integrating circuits. In order to measure peak values of pulsed fields, the values displayed on the instrument have to be compensated. This is done by applying corrective curves, established by simulating the whole instrument and the pulsed source. Two different kinds of corrective curves have been established: "static" and "dynamic". "Static" curve gives a relationship between the E_{rms} and the displayed electric field value, whereas the "dynamic" curve takes into account the aerial rotation speed, as well as the antenna beam width of the scanning radar antenna and gives a relationship between $E_{\text{peak}}/32$ and the displayed electric field value. The "static" correction curves have been checked by the performed laboratory measurements for the both probes. The basis for the curves are, except for knowing the characteristics of the device, an additional knowledge of four parameters of a scanning radar: pulse width, pulse repetition frequency, aerial rotation speed and antenna beam width. If the mentioned parameters are known, it is possible to relate a value displayed on the instrument to the peak electric field value, irradiated by the scanning radar antenna. It should be taken into account that here presented results are valid only for the very specific instrument (Wandel & Goltermann EMR-300 with the probes type 8 and 9) and for the scanning radar.

In conclusion, it seems that one more very complex problem of measuring peak electric fields generated by a scanning radar antenna has been solved, representing thus the best available solution for an inexpensive electric field meter. Of course, more complex situations with two radar transmitters in the close environment or when radar transmitter parameters are not known need to be researched and characterized in the future work.

REFERENCES

- [1] J. Lin, "On microwave-induced hearing sensation," *IEEE Transactions on Microwave Theory and Techniques*, 25, pp. 605-613, 1977
- [2] IRPA/INIRC guidelines, Chapter 5 "Guidelines on limits of exposure to radiofrequency electromagnetic fields in the frequency range from 100 kHz to 300 GHz", 1991
- [3] ENV 50166-2: "Human exposure to electromagnetic fields - High frequency (10 kHz to 300 GHz)", CENELEC, 1995
- [4] H. I Bassen, G. S. Smith, "Electric Field Probes - A Review," *IEEE Transactions on Antennas and Propagation*, Vol. AP-31(5), September 1983, pp. 710-718
- [5] General Microwave, RAHAM Radiation Hazard Meters, Technical Data of Radiation Hazard Meters 81, 83, 91, 93, 1992
- [6] LORAL, Microwave Narda, Technical Specifications of Electric Field Probes, Models 8721 & 8723, 1994
- [7] M. Kanda, "An Electromagnetic Near-Field Sensor for Simultaneous Electric and Magnetic-Field Measurements, " *IEEE Transactions on Electromagnetic Compatibility*, Vol. EMC-26, August 1984, pp. 102-110
- [8] M. Kanda, "Analytical and Numerical Techniques for Analyzing an Electrically Short Dipole with a Nonlinear Load," *IEEE Transactions on Antennas and Propagation*, Vol. AP-28 (1), January 1980, pp. 71-78
- [9] J. Randa, M. Kanda, "Multiple-Source, Multiple-Frequency Error of an Electric Field Meter," *IEEE Trans. on Antennas and Propagation*, Vol. AP-33(1), January 1985, pp. 2-9
- [10] Wandel & Goltermann, Technical Data of Electric Field Meter EMR-300 and Probes Type 8 and 9, 1996
- [11] H. Keller, R. Bitzer, "Technische Problemlösungen bei der Entwicklung von Messgeräten fuer nichtionisierende Strahlung," *EMV Symposium*, 4-6.10.1995 an der BAKWT, Mannheim, 1995, pp. 1.7.1-1.7.4
- [12] M. Schallner, F.M. Landstorfer, R. Bitzer, "A Compact, Broadband Electrical Field Probe," *EMC Roma 96*, 1996, pp. 394-398
- [13] R. Bitzer, "Breitbandiges Feldstärkemesssystem bis 18 GHz," *EMV Kompendium*, 1997, pp. 264-267